

FFVL11 Cable drum

Images:

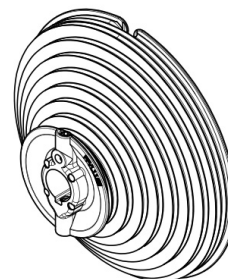
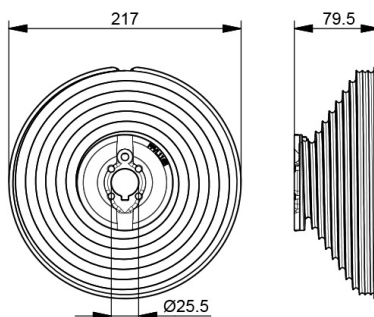

Description:

| | |
|-------------------------|--|
| - Subcategory | : 04. Industrial - VL |
| - IND/RES | : IND |
| - Full package quantity | : 10 |
| - Unit | : pair (2) |
| - Weight / Unit | : 1,8kg |
| - Material | : Aluminium |
| - Length | : 79,5mm |
| - Product Family | : 15 Cable drums |
| - Inside diameter | : 25,5mm |
| - Max. cable diameter | : 5mm |
| - Max. door weight | : 500kg |
| - Outside diameter | : 217mm |
| - Safety windings | : 2 |
| - Shaft Size | : 1" |
| - Marking | : Red = Left, Black = Right |
| - Technical description | : Lifting cable provided with terminal (pressed Aluminium sleeve) can be hooked into camber of the drum or passed through drum and fixed with a hollow-head screw. Easy cable adjustment. Drum will be fixed to shaft through key by 1 hollow-head screw M8. |