

670LH Spring break device

Images:

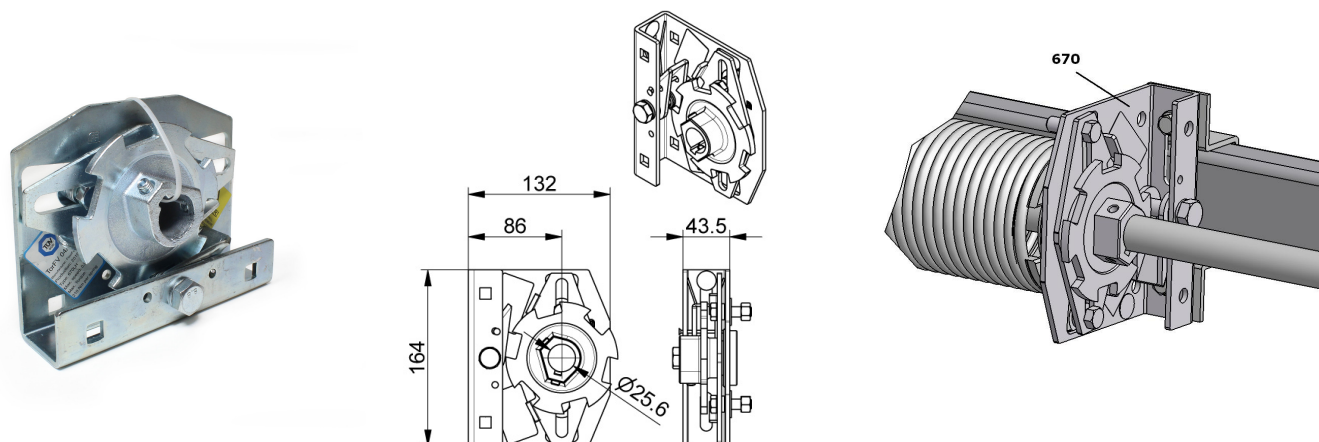

Description:

- | | |
|-------------------------|---|
| - Subcategory | : 02. Industrial |
| - IND/RES | : IND |
| - Full package quantity | : 15 |
| - Unit | : piece (1) |
| - Weight / Unit | : 1,65kg |
| - Material | : Galvanised Steel |
| - Height | : 164mm |
| - Product Family | : a 009 |
| - Heart-to-heart | : 86mm |
| - Inside diameter | : 25,4mm |
| - Technical description | : Suitable for use with one torsion spring. For heart distance bigger than 86mm, combine with the adjustable plate 661E, 322BAS or 662N. See detailed manual. |