

## 595RSF Roller

### Images:

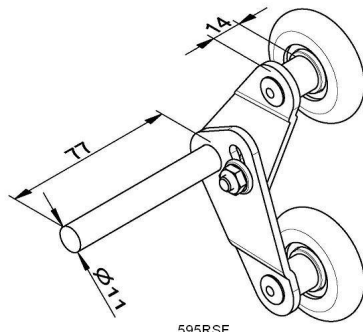

### Description:

- Subcategory	: 02. Tandem
- IND/RES	: RES
- Full package quantity	: 50
- Unit	: piece (1)
- Weight / Unit	: 0,33kg
- Material	: Nylon, Galvanised Steel
- Colour	: White
- Length	: 77mm
- Thickness	: 11mm
- Product Family	: a 024
- Outside diameter	: 46,5mm
- Marking	: 595RSF FF
- Commercial description	: springs in front (F)
- Technical description	: New solution. Smart design. Panel adjustment can be achieved with this roller in combination with flat side hinges (424FZN etc.). Smooth running of the door. Part of Value Pack Silent.