

1134HIL Hinge

Images:

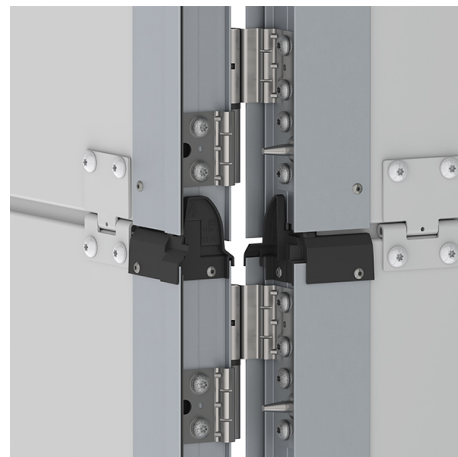
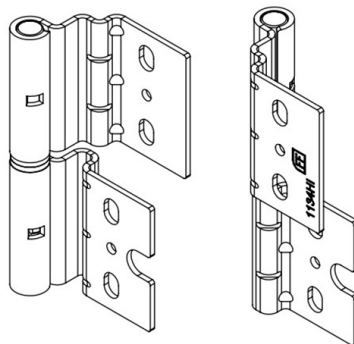

Description:

- | | |
|--------------------------|---|
| - Subcategory | : 08. SolidStep |
| - IND/RES | : BOTH |
| - Full package quantity | : 24 |
| - Unit | : piece (1) |
| - Weight / Unit | : 0,163kg |
| - Product Family | : a 001§ |
| - Commercial description | : Pass Door Hinge |
| - Technical description | : SolidStep pass door hinge for left handed doors. Use in combination with 1134P. |