

SDL-NB-HKENG Chain link

Images:

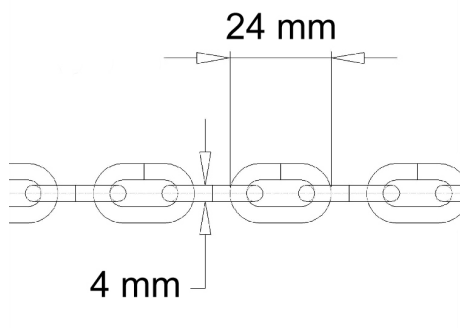

Description:

- | | |
|-------------------------|---|
| - Subcategory | : Industrial, Nice accessories |
| - IND/RES | : IND |
| - Full package quantity | : 50 |
| - Unit | : bag (50) |
| - Weight / Unit | : 0,20kg |
| - Material | : Galvanised Steel |
| - Product Family | : a 110 |
| - Technical description | : To connect chain lengthenings to Nice chains like SDL-NB-HKE. |